

# LOSCAM

*Your Pooling Solutions Partner*

## Loscam Pallet Cage



Model: C3



[www.loscam.com](http://www.loscam.com)

# Loscam Pallet Cage

The Loscam Pallet Cage has been developed with the particular needs of our customers in mind. Ideal for storing and moving difficult to handle freight or freight high in value that require additional protection.

For long term hire arrangements, the Pallet Cages are able to be configured for individual needs.

## Benefits

- Retail friendly with fold-down sides to enable consumer access to products
- Reduced need for outer packaging materials, such as shrink film, which decreases wastage and reduces carbon footprint
- Connects easily to existing pallets and collapses for efficient reverse logistics
- Easy to disassemble, fold and store to save space and recovery cost
- Stackable and stable allowing vertical product storage solution in warehouses and in transport
- Stacking plates designed for easy forklift stacking and improved handling efficiency
- Maximises cube utilisation of vehicles
- Modular design, repairable and replaceable parts to reduce maintenance costs
- Optional accessories like shelf and mat to meet customer's logistics operations

## Specification

Overall Size:	1200 mm(L) x 1000 mm(W) x 1000 mm(H)
With Shelf Insert	500 mm (height of shelf from base)
Maximum Load (Base Cage)	750 kg
Approximate Weight	50 kg
Maximum Stacked (Static)	3 cages
Finishing	Electrostatic spray coated
Uses:	Applicable for distribution centres, manufacturing, operations, delivery, retail and display.

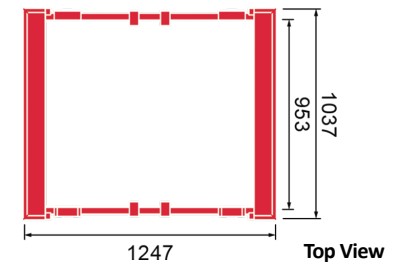
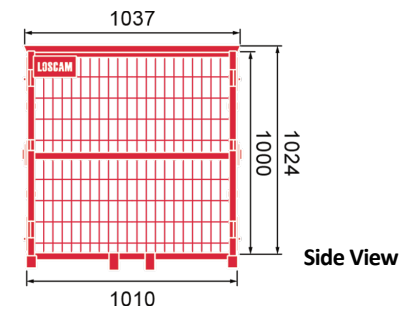
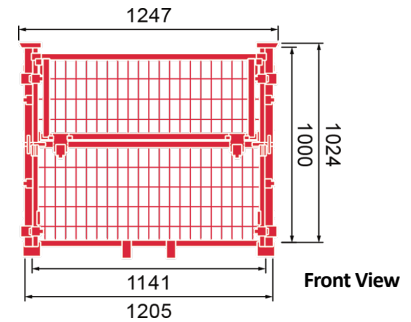

Pallet Cage



Folded

Copyright © LOSCAM. All Right Reserved.  
© Loscam International Holdings Co., Limited

# LOSCAM

### South East Asia

#### Regional Office

14th Floor, Lumpini Tower  
1168/96 Rama IV Rd  
Tungmahamek  
Sathorn, Bangkok  
10120 Thailand  
Ph: 66 2613 0700  
Fax : 66 2613 0799

#### Malaysia

Lot 22, Jalan Player 15/1  
Seksyen 15, Shah Alam,  
Selangor, 40200 Malaysia  
Ph: 60 3 5511 7066  
Fax: 60 3 5511 7062

#### Thailand

169/3 – 14, Moo 5 T. Lumsai  
Aumphur Wang Noi  
Ayutthaya 13170, Thailand  
Ph: 66 3527 6888  
Fax : 663527 6897 (Operations)  
66 3527 6898-9 (Customer Services)

#### Philippines

Suite 301 Common Goal Tower  
Finance Corner Industry Streets  
Madrigal Business Park  
Ayala Alabang Muntinlupa City  
1770 Philippines  
Ph: 63 8842 7878

#### Vietnam

526 Binh Duong Avenue,  
Nguyen Trai Quarter,  
Lai Thieu Ward, Thuan An City,  
Binh Duong Province  
Ph: 84 27 4376 9199

#### Singapore

37 Joo Koon Circle, Jurong  
Singapore 629062  
Ph: 65 6863 0316  
Fax: 65 6863 0312