

# LOSCAM

*Your Pooling Solutions Partner*

## Loscam Wooden Pallets - Greater China



Model: WP

Customer Service: 400 808 1942

# Loscam Wooden Pallet - Greater China

## Benefits of Loscam

- Loscam pallets are available when and where you need them
- ECR approved design - industry standard for retail pallet pooling
- Pallet Hire Management System (HMS) enables customers to track pallets movement between trading partners

## Specifications:

Overall Size:	1200 mm(L) x 1000 mm(W) x 156 mm(H)
Tare Weight:	28 kg*
Dynamic Load:	1.5 t
Static Load:	6 t
Forklift Access:	<ul style="list-style-type: none"><li>• 4-way entry points</li><li>• Stackable/ rackable</li></ul>
Uses:	<ul style="list-style-type: none"><li>• Storage for all types of products</li><li>• Movement of products between factories and warehouses</li><li>• Transfer of products to retailers</li><li>• Ideal for pallet magazines and automated production lines</li></ul>

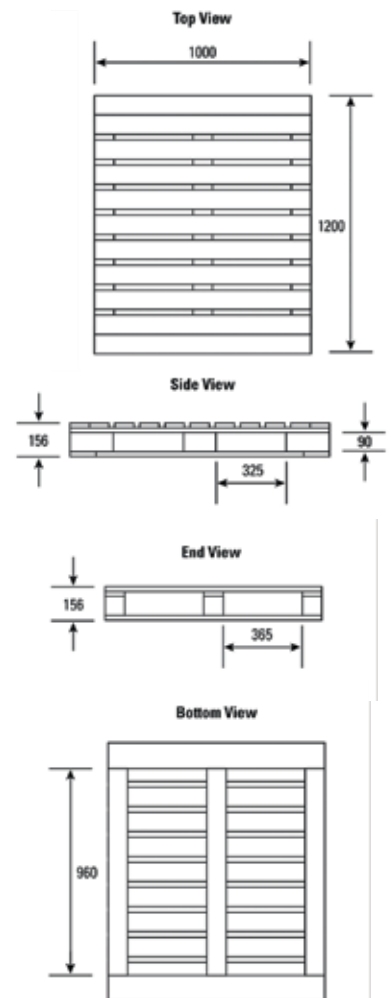

Copyright © LOSCAM. All Right Reserved.  
© Loscam International Holdings Co., Limited

# LOSCAM

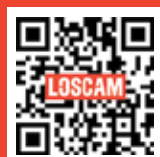

400-808-1942 

info.china@loscam.com 

www.loscam.com.cn 